

NOTE
 MATERIAL
 INSULATOR: PBT +30%GF
 CONTACTS: BRASS
 SHELL: COLD ROLLED STEEL
 CONTACT PLATING: GOLD PLATING OVER NICKEL
 ELECTRICAL SPECIFICATION
 CURRENT RATING: 1A;
 CONTACT RESISTANCE: 30mΩ MAX.
 INSULATION RESISTANCE: 500MΩ MIN 500V DC.
 DIELECTRIC WITHSTANDING VOLTAGE: 500V AC
 ENVIRONMENTAL
 OPERATING TEMPERATURE: -55°C~105°C.
 PART NO. DESCRIPTION:

10 3-XX 1 X 0 X XX 01

SERIES NO: _____ SERIAL NUMBER
 PRODUCT KIND _____ COLOR CODE: 01=WHITE
 PIN NUMBER _____ 02=BLACK 05=BLUE
 FEMALE _____ PLATING CODE:
 A=1u'; B=3u'
 NUT TYPE: 1=NO LOCK NUT _____ USELESS
 2=LOCK NUT, 3=ADD NUT

PRODUCTS NO	DIMENSIONS					
	A	B	C	D	E	F
DB-09M	30.80	25.00	16.92	8.30	12.55	5.90
DB-15M	39.20	33.32	25.25	8.30	12.55	5.90
DB-19M	44.80	38.86	30.60	8.30	12.55	5.90
DB-23M	50.30	44.30	36.10	8.30	12.55	5.90
DB-25M	53.05	47.04	38.96	8.30	12.55	5.90
DB-37M	69.40	63.50	55.42	8.30	12.55	5.90

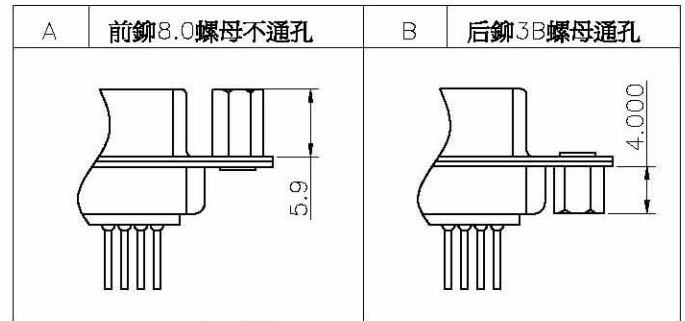

-TOLERANCES- UNLESS OTHERWISE SPECIFIED 公差參考表		GC ELECTRONIC CO.LTD.					
X.X ±0.25	X.X' ±3"	APPD:	TITLE: D-SUB MALE DIP180° SOCKET 成品				
X.XX ±0.15	X.XX' ±1"		CHECK:	DATE	SCALE	UNIT	TYPE
X.XXX ±0.10	X.XXX' ±0.5"	DRAW:	2005.09.30	FREE	MM	Z	1